

Quality Construction — Always One Step Ahead

LED Exterior Lighting

LED lights are proven to be brighter for improved safety, more durable requiring less maintenance, and more efficient consuming 90% less power reducing the load on the tow vehicle's electrical system as compared to traditional incandescent or bulb style lights. Stop/Tail/Turn lights feature an exclusive wraparound design.



Wet Cell Battery

Essential part of breakaway system. Applies trailer's full braking capacity for a minimum of 15 minutes meeting D.O.T. requirements. Low voltage indicator light. Up to 100 recharges.



Since 1954

Landscape Trailers



Ramp Door & Corner Post Jacks

Full width hinge with free floating 3/4" steel pin. Stronger than strap hinges. Welded perimeter door frame with gussets at major stress points. Full length reinforcements prevent bowing. Spring assist cable(s) for safety. Rear corner post stabilizer jacks with steel tube post are coated in Zincdychromate for rust resistance.



Full Width Hinge with 3/4" Steel Pin

12 Volt Electrical System

All 12-Volt wiring is completely weather protected with no direct exposure to the elements or road hazards. Starting at the sealed A-frame junction box, the molded, 4-wire cable is routed inside the tubular main rail. All brake wiring is run through a plastic conduit into a special welded channel on the axle.



Welded Protective Channel on Axle

Aluminum Anti-Rack Cam Lock

Commercial quality cast aluminum Cam Lock and stainless steel hasp deliver a long lasting, no-rust finish for the life of your trailer. Anti-Rack design (forked Cam with "T" shaped Keeper) forms a structural link between door header and footer reducing door movement, frame torque, and road vibration. Better seal compression to prevent moisture penetration.

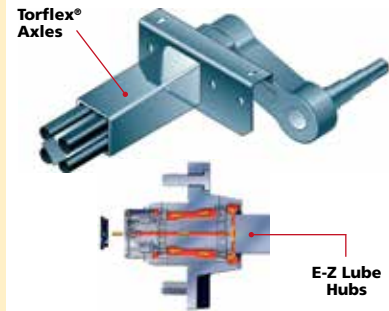

Torflex® Axles

E-Z Lube Hubs

Torflex® Rubber Ride Axles with E-Z Lube Hubs

Equipped with Torflex® rubber torsion suspension system with progressive torque action and independent wheel movement for maximum shock absorption and road stability. E-Z Lube hubs with outside grease fittings for bearing lubrication without disassembly. E-Coated wheels and brand name radial tires.

Superior Frame Construction

A Wells Cargo frame is a product of the industry's best engineering and designed to provide over 15 years of daily service. Heavy-duty tubular steel main rails and full height C-channel crossmembers deliver commercial grade durability. Radius steel corner posts, front and rear, extend to the bottom of the frame providing the maximum welding surface possible.

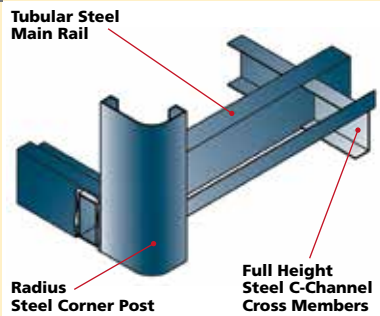

Tubular Steel Main Rail

Radius Steel Corner Post

Full Height Steel C-Channel Cross Members

Corrosion Preventive Measures

Every Wells Cargo chassis is protected with a laboratory tested, Corrosion Preventive Compound (CPC), to help deter the accumulation of rust. Painted steel surfaces feature a state-of-the-art process including both a primer & urethane topcoat for a smooth, long lasting finish. Also, a special corrosion resistant barrier is applied between the steel frame and exterior aluminum skin to prevent electrolysis.



Look for the NATM Decal

Wells Cargo is a proud member of the National Association of Trailer Manufacturers (NATM). Their decal signifies compliance with established industry standards and manufacturing practices. It also certifies your Wells Cargo trailer meets all federal requirements including the Federal Motor Vehicle Safety Standards (FMVSS).



Solid Support Down The Road

After you make the decision to buy a Wells Cargo trailer, our commitment to you is not over. Our comprehensive 6-Year "Never Look Back" Warranty Program is more than just words. It's about how quickly and responsibly we respond to your needs. It's the peace-of-mind you get knowing your investment is protected by an established company with a solid reputation.



AUTHORIZED WELLS CARGO DEALER

Green Industry Workhorse

©Wells Cargo, Inc. 2010 LITHO USA Form LS805R0712

WELLS CARGO

Elkhart, IN

Waycross, GA

Waco, TX

Ogden, UT

McAdoo, PA

www.wellscargo.com

With a Wells Cargo Behind... You Never Look Back!™



LS Series Landscape Trailer



You're in a tough profession. It takes business savvy, determination, and a lot of hard work to succeed. Wells Cargo can help you out in the hard work department. From transporting all your tools of the trade to projecting a professional image, a Wells Cargo **LS Series** landscape trailer has the "right stuff" to get the job done. We're used to the punishment a work crew can dish out and we don't mind getting a little dirt under our treads. For that reason, all **LS Series** landscape trailers are built with plenty of muscle and backbone to spare. Think of your Wells Cargo **LS Series** landscape trailer as an investment in durable goods.

At Wells Cargo, we're dedicated to building the most reliable trailers on the road today and winning you over as a satisfied customer. Our reputation for long lasting durability stems from a heavy-duty steel frame that doesn't need pampering. No shortcuts. No cutting corners. Just the strongest frame construction available and customized the way you want it. Every **LS Series** landscape trailer is engineered to deliver hassle-free performance . . . day in and day out. It's no surprise that we can confidently tell you to plan on at least 15 years of carefree service.



Customizing Options

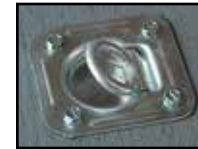

Floor Tie-Off



Aluminum Wheels



Ramp Door Extension



ATP Wall Guard and 1 1/2" T & G Flooring



Workbench with Overhead Cabinets



Wall Tie-Off



LED Amber Strobe Safety Light Package

This recommended option provides increased safety on the job site. The LED Amber Strobes, mounted on the rear end cap, are activated whenever the rear ramp door is in the lowered (open) position.

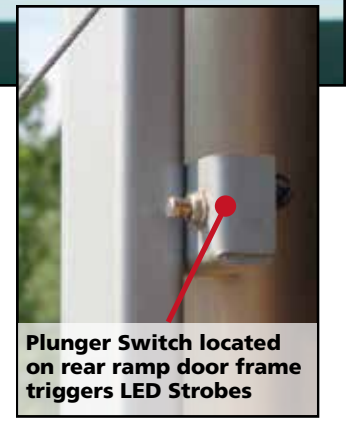

Plunger Switch located on rear ramp door frame triggers LED Strobes



Cargo Control Systems (E-Track)



High Security Cam Lock



Document Holder

LS Series Includes:



Heavy-Duty Anodized Aluminum Roof Cove

Flow-Thru Side Vents

Side Entry Door

3/8" Plywood Sidewalls

Rear Ramp Door with Spring Assist

Slip Resistant Extruded Aluminum Ramp Edge Protector

3/4" Pressure Treated Plywood Floor

3/4" Pressure Treated Plywood Ramp Deck

Protective Barrier Between Floor and Sidewall

Corner Post Stabilizer Jacks

Frame Crossmembers on 16" Centers

Aluminum Tread Plate Fenders (Not available on certain models.)



- ATP Stone Guard
- Spare Tire Carrier
- Spare Tire & Wheel
- Tire Cover
- Fuel Rack (Not included in LS Series. See Tool Organizer Package.)



• First Aid Kit



- 12 Volt Dome Light
- Wall Switch

Tool Organizer Package



1



2



3



4



5



6



7



8



9

- 1.) Water Cooler Rack
- 2.) Back-Pack Blower Rack
- 3.) Hedge Trimmer Rack
- 4.) 5-Gallon Gas Can
- 5.) Hand Tool Rack
- 6.) Back Pack Sprayer Rack
- 7.) Line Trimmers Rack
- 8.) Blade Holder
- 9.) Metal Storage Bin

Trailers shown feature optional equipment available at additional charge. Specifications, features and available options subject to change without notice.